

HARDDISKS

PC-Support Information Pages for various at Hard Disks and other Storage Drives

Connector pin assignment for: Floppy Disk Drive, IDE-Bus / AT-Bus, MFM/RLL Hard Disk Connector, ESDI Hard Disk Connector, SCSI - Bus: 25 pin SCSI Connector (Apple), 50 pin SCSI Connector (A-Cable), 68 pin SCSI Connector, 110 pin SCSI Connector (L-Cable).

Filename : e_dta-pc-tech-disk.htm

Location : <http://www.elektroniklager.de/pc-sup>

Copyright, all rights reserved, Eberhard De Wille

Revision History:

| Date | Version | Revision | Name | Department | Phone | Description of Changes |
|------------|---------|----------|-------------------|------------|-------|-------------------------------------|
| 2004-06-01 | 1.0 | a | Eberhard De Wille | pc-sup | - | First version of the hard disk page |

Table of contents

1. Floppy Disk Drive 34 Pin Connector 4

2. IDE - Bus / AT - Bus..... 5

3. MFM/RLL Hard Disk Connector (34 Pin Control Cable and 20 Pin Data Cable)..... 7

4. ESDI Hard Drive Connector (34 Pin Control Cable and 20 Pin Data Cable)..... 8

5. SCSI Bus 9

 5.1. 25 pin SCSI Connector (Apple)..... 10

 5.2. 50pin SCSI Connector (A-Cable) 10

 5.3. 68pin SCSI Connector 11

 5.4. 110pin SCSI-Connector (L-Cable) 13

1. Floppy Disk Drive 34 Pin Connector

| Pin | Signal |
|-----|-------------|
| 2 | LDENSEL# |
| 4 | Microfloppy |
| 6 | EDENSEL |
| 8 | INDX# |
| 10 | MTEN1# |
| 12 | DRSEL0# |
| 14 | DRSEL1# |
| 16 | DTENO# |
| 18 | DIR# |
| 20 | STP# |
| 22 | WRDATA# |
| 24 | WREN# |
| 26 | TRK0# |
| 28 | WRPRDT# |
| 30 | RDDATA# |
| 32 | HDSEL1# |
| 34 | DSKCHG# |

All odd numbered pins are connected to ground (GND)

Simplified drawing, view upon:

34 pin printed circuit board connector (5,25" drives)



34 PIN connector (3,5" drives)

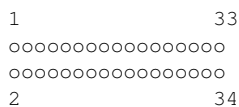

The printed circuit board connector and the connector of the 3,5" drives are mounted on the opposite side at the older type of universal cable sets. The cable has to be twisted between the 5,25" and 3,5" drives. Pin 1 is usually marked red at the cable.

2. IDE - Bus / AT - Bus

| IDE Signal | Pin | Function | AT-Signal | Signal Direction |
|------------|-----|---------------------------------|--------------|------------------|
| RESET | 1 | Reset drives | RESET DRV 1) | Host->Drive |
| GND | 2 | Ground | -- | -- |
| DD7 | 3 | Data bus 7 | SD7 | bi-directional |
| DD8 | 4 | Data bus 8 | SD8 | bi-directional |
| DD6 | 5 | Data bus 6 | SD6 | bi-directional |
| DD9 | 6 | Data bus 9 | SD9 | bi-directional |
| DD5 | 7 | Data bus 5 | SD5 | bi-directional |
| DD10 | 8 | Data bus 10 | SD10 | bi-directional |
| DD4 | 9 | Data bus 4 | SD4 | bi-directional |
| DD11 | 10 | Data bus 11 | SD11 | bi-directional |
| DD3 | 11 | Data bus 3 | SD3 | bi-directional |
| DD12 | 12 | Data bus 12 | SD12 | bi-directional |
| DD2 | 13 | Data bus 2 | SD2 | bi-directional |
| DD13 | 14 | Data bus 13 | SD13 | bi-directional |
| DD1 | 15 | Data bus 1 | SD1 | bi-directional |
| DD14 | 16 | Data bus 14 | SD14 | bi-directional |
| DD0 | 17 | Data bus 0 | SD0 | bi-directional |
| DD15 | 18 | Data bus 15 | SD15 | bi-directional |
| GND | 19 | Ground | -- | -- |
| 2) | 20 | Mark for Pin 20 | -- | -- |
| DMARQ 3) | 21 | DMA Request | DRQx | Drive->Host |
| GND | 22 | Ground | -- | -- |
| DIOW | 23 | Write data via I/O-channel | IOW | Host->Drive |
| GND | 24 | Ground | -- | -- |
| DIOR | 25 | Read data via I/O-channel | IOR | Host->Drive |
| GND | 26 | Ground | -- | -- |
| IORDY 3) | 27 | I/O-access done (ready) | IOCHRDY | Drive->Host |
| SPSYNC | 28 | Spindle synchronization | -- | Drive->Drive |
| DMACK 3) | 29 | DMA Acknowledge | DACKx | Host->Drive |
| GND | 30 | Ground | -- | -- |
| INTRQ | 31 | Interrupt Request | IRQx | Drive->Host |
| IOCS16 | 32 | 16-Bit-Transfer via I/O-channel | I/OCS16 | Drive->Host |
| DA1 | 33 | Address bus 1 | SA1 | Host->Drive |
| PDIAG | 34 | Passed Diagnostic from Slave | -- | Laufw.->Laufw. |
| DA0 | 35 | Address bus 0 | SA0 | Host->Drive |
| DA2 | 36 | Address bus 2 | SA2 | Host->Drive |
| CS1Fx | 37 | Chip Select for basisadr. 1f0h | -- | Host->Drive |
| CS3Fx | 38 | Chip Select for basisadr. 3f0h | -- | Host->Drive |
| DASP | 39 | Drive Active/Slave Present | -- | Drive->Host |
| GND | 40 | Ground | -- | -- |

- 1) inverted signal of the AT bus signal
- 2) pin closed, to prevent a wrong plugging of the connector
- 3) optional

Simplified drawing, view upon:

40 Pin IDE Cable

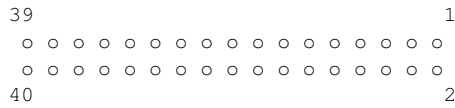

At some cables pin 20 is coded i.e. closed to prevent a wrong placement of the cable. Pin 1 is marked by a color (red). At the 44 pin notebook cables the signal assignment is the same as shown for the 40 pin cables.

Simplified drawing, view upon:

44 Pin cable for 2,5" Drives (hard disk in notebooks)

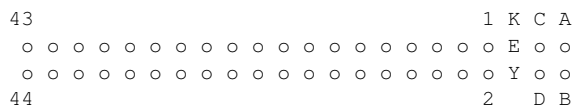

At the 44 pin notebook cables the signals have the same assignment as for the 40 pin cables. The 44 pin cable is physically a 50 pin cable. 2 pins were removed to match the divider in the socket. Pins A-D are not used.

Further information you find at Seagate at: <ftp://ftp.seagate.com/techsuppt/misc/pin-cabl.txt>

3. MFM/RLL Hard Disk Connector (34 Pin Control Cable and 20 Pin Data Cable)

MFM/RLL 34 Pin Control Cable

| Pin | Signal | Pin | Signal |
|-----|--------|-----|---------------|
| 1 | GND | 2 | Head Sel 8 |
| 3 | GND | 4 | Head Sel 4 |
| 5 | GND | 6 | Write Gate |
| 7 | GND | 8 | Seek Complete |
| 9 | GND | 10 | Track 0 |
| 11 | GND | 12 | Write Fault |
| 13 | GND | 14 | Head Sel 2 |
| 15 | GND | 16 | (reserved) |
| 17 | GND | 18 | Head Sel 2 |
| 19 | GND | 20 | Index |
| 21 | GND | 22 | Ready |
| 23 | GND | 24 | Step |
| 25 | GND | 26 | Drive Sel 1 |
| 27 | GND | 28 | Drive Sel 2 |
| 29 | GND | 30 | Drive Sel 3 |
| 31 | GND | 32 | Drive Sel 4 |
| 33 | GND | 34 | Direction In |

MFM/RLL 20 Pin Data Cable

| Pin | Signal | Pin | Signal |
|-----|----------------|-----|----------------|
| 1 | Drive Selected | 2 | GND |
| 3 | (reserved) | 4 | GND |
| 5 | (reserved) | 6 | GND |
| 7 | (reserved) | 8 | GND |
| 9 | (reserved) | 10 | (reserved) |
| 11 | GND | 12 | GND |
| 13 | Write Data+ | 14 | Write Data- |
| 15 | GND | 16 | GND |
| 17 | Read Data+ | 18 | NRZ Read Data- |
| 19 | GND | 20 | GND |

4. ESDI Hard Drive Connector (34 Pin Control Cable and 20 Pin Data Cable)

ESDI 34 Pin Control Cable

| Pin | Signal | Pin | Signal |
|-----|--------|-----|-------------------|
| 1 | GND | 2 | Head Sel 3 |
| 3 | GND | 4 | Head Sel 2 |
| 5 | GND | 6 | Write Gate |
| 7 | GND | 8 | Config/Stat Data |
| 9 | GND | 10 | Transfer Ack |
| 11 | GND | 12 | Attn |
| 13 | GND | 14 | Head Sel 0 |
| 15 | GND | 16 | Sect/Add MK Found |
| 17 | GND | 18 | Head Sel 1 |
| 19 | GND | 20 | Index |
| 21 | GND | 22 | Ready |
| 23 | GND | 24 | Trans Req |
| 25 | GND | 26 | Drive Sel 1 |
| 27 | GND | 28 | Drive Sel 2 |
| 29 | GND | 30 | Drive Sel 3 |
| 31 | GND | 32 | Read Gate |
| 33 | GND | 34 | Command Data |

ESDI 20 Pin Data Cable

| Pin | Signal | Pin | Signal |
|-----|-----------------|-----|-------------------|
| 1 | Drive Selected | 2 | Sect/Add MK Found |
| 3 | Seek Complete | 4 | Addr Mark Enable |
| 5 | (reserved) | 6 | GND |
| 7 | Write Clk+ | 8 | Write Clk- |
| 9 | Cartridge Chng | 10 | Read Ref Clk+ |
| 11 | Read Ref Clk- | 12 | GND |
| 13 | NRZ Write Data+ | 14 | NRZ Write Data- |
| 15 | GND | 16 | GND |
| 17 | NRZ Read Data+ | 18 | NRZ Read Data- |
| 19 | GND | 20 | GND |

5. SCSI Bus

Picture: Schematic of the SCSI Bus (11k)

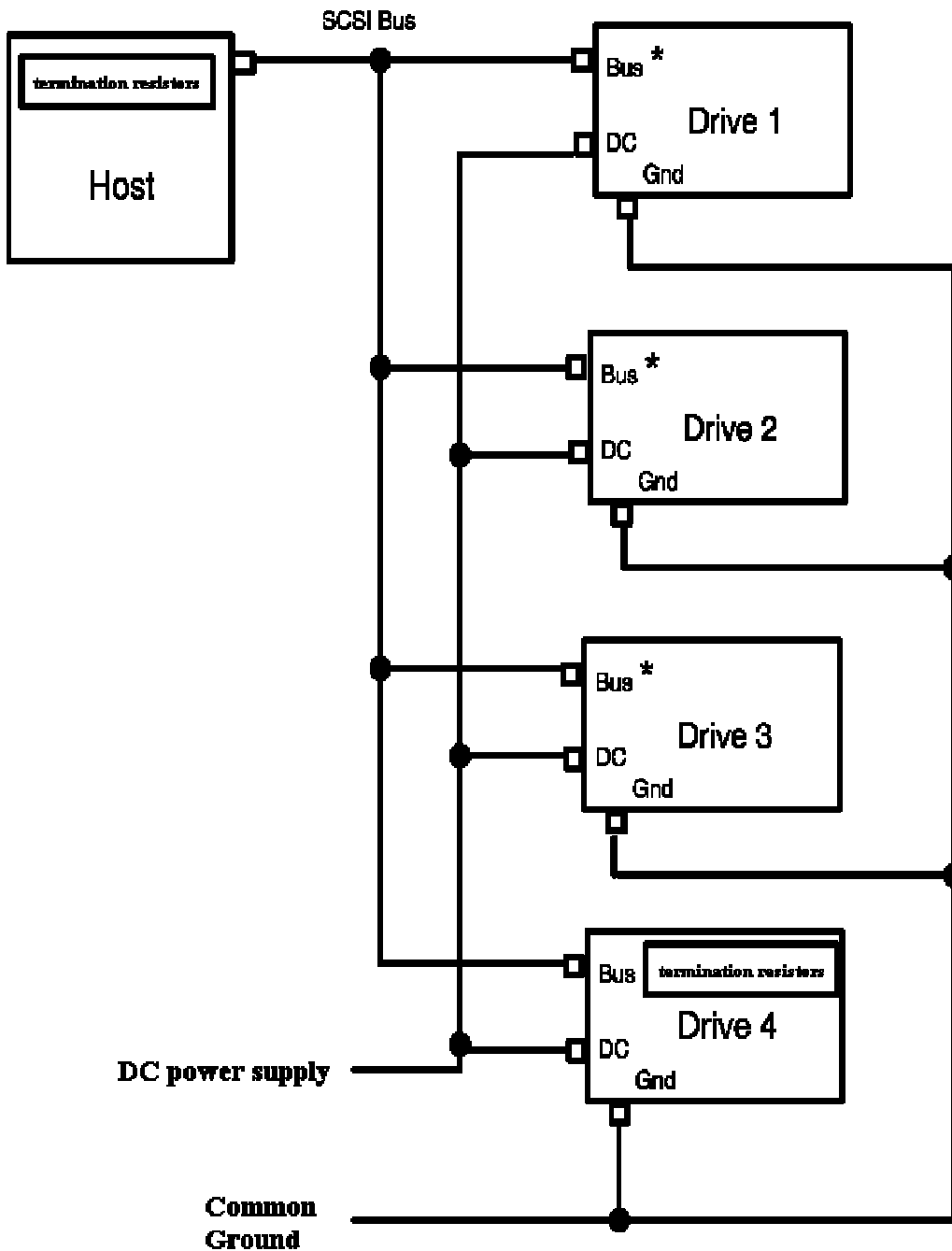

*** no termination resistor are allowed here**

5.1. 25 pin SCSI Connector (Apple)

| Pin | Signal |
|-----|----------------------|
| 1 | -REQ |
| 2 | -MSG |
| 3 | -I/O |
| 4 | -RST |
| 5 | -ACK |
| 6 | -BSY |
| 7 | GND |
| 8 | -DB[0] |
| 9 | GND |
| 10 | -DB[3] |
| 11 | -DB[5] |
| 12 | -DB[6] |
| 13 | -DB[7] |
| 14 | GND |
| 15 | -C/D |
| 16 | GND |
| 17 | -ATN |
| 18 | GND |
| 19 | -SEL |
| 20 | -DB[P] |
| 21 | -DB[1] |
| 22 | -DB[2] |
| 23 | -DB[4] |
| 24 | -GND |
| 25 | -TRMPWR ¹ |

¹At the Macintosh Plus the TERMPWR line is not used. The SCSI device has to generate the voltage for the termination resistors.

5.2. 50pin SCSI Connector (A-Cable)

| Pin | Single-Ended | | Differential | |
|------|--------------|--------|--------------|----------|
| | 2,3 | 1 | 2,3 | 1 |
| Plug | 2,3 | 1 | 2,3 | 1 |
| 1 | GND | GND | GND | GND |
| 2 | GND | -DB[0] | +DB[0] | GND |
| 3 | GND | GND | +DB[1] | +DB[0] |
| 4 | GND | -DB[1] | +DB[2] | -DB[0] |
| 5 | GND | GND | +DB[3] | +DB[1] |
| 6 | GND | -DB[2] | +DB[4] | -DB[1] |
| 7 | GND | GND | +DB[5] | +DB[2] |
| 8 | GND | -DB[3] | +DB[6] | -DB[2] |
| 9 | GND | GND | +DB[7] | +DB[3] |
| 10 | GND | -DB[4] | +DB[P] | -DB[3] |
| 11 | GND | GND | DIFFSENS | +DB[4] |
| 12 | Res | -DB[5] | Res. | -DB[4] |
| 13 | NC | GND | TRMPWR | +DB[5] |
| 14 | Res | -DB[6] | Res. | -DB[5] |
| 15 | GND | GND | +ATN | +DB[6] |
| 16 | GND | -DB[7] | GND | -DB[6] |
| 17 | GND | GND | +BSY | +DB[7] |
| 18 | GND | -DB[P] | +ACK | -DB[7] |
| 19 | GND | GND | +RST | +DB[P] |
| 20 | GND | GND | +MSG | -DB[P] |
| 21 | GND | GND | +SEL | Diffsens |
| 22 | GND | GND | +C/D | GND |
| 23 | GND | Res. | +REQ | Res. |
| 24 | GND | Res. | +I/O | Res. |
| 25 | GND | NC | GND | TRMPWR |
| 26 | -DB[0] | TRMPWR | GND | TRMPWR |
| 27 | -DB[1] | Res. | -DB[0] | Res. |
| 28 | -DB[2] | Res. | -DB[1] | Res. |
| 29 | -DB[3] | GND | -DB[2] | +ATN |
| 30 | -DB[4] | GND | -DB[3] | -ATN |
| 31 | -DB[5] | GND | -DB[4] | GND |
| 32 | -DB[6] | -ATN | -DB[5] | GND |
| 33 | -DB[7] | GND | -DB[6] | +BSY |
| 34 | -DB[P] | GND | -DB[7] | -BSY |
| 35 | GND | GND | -DB[P] | +ACK |
| 36 | GND | -BSY | GND | -ACK |
| 37 | Res | GND | Res. | +RST |
| 38 | TRMPWR | -ACK | TRMPWR | -RST |
| 39 | Res | GND | Res. | +MSG |
| 40 | GND | -RST | -ATN | -MSG |
| 41 | -ATN | GND | GND | +SEL |
| 42 | GND | -MSG | -BSY | -SEL |
| 43 | -BSY | GND | -ACK | +C/D |
| 44 | -ACK | -SEL | -RST | -C/D |
| 45 | -RST | GND | -MSG | +REQ |
| 46 | -MSG | -C/D | -SEL | -REQ |
| 47 | -SEL | GND | -C/D | +I/O |
| 48 | -C/D | -REQ | -REQ | -I/O |
| 49 | -REQ | GND | -I/O | GND |
| 50 | -I/O | I/O | GND | GND |

Connector Type: Post (1), Centronics (2), SCSI-2-High-Density (3)

5.3. 68pin SCSI Connector

| Pin | Single-Ended | | Differential | |
|-----|--------------|---------|--------------|----------|
| | B-Cable | P-Cable | B-Cable | P-Cable |
| 1 | GND | GND | GND | +DB[12] |
| 2 | GND | GND | +DB[8] | +DB[13] |
| 3 | GND | GND | +DB[9] | +DB[14] |
| 4 | GND | GND | +DB[10] | +DB[15] |
| 5 | GND | GND | +DB[11] | +DB[P1] |
| 6 | GND | GND | +DB[12] | GND |
| 7 | GND | GND | +DB[13] | +DB[0] |
| 8 | GND | GND | +DB[14] | +DB[1] |
| 9 | GND | GND | +DB[15] | +DB[2] |
| 10 | GND | GND | +DB[P1] | +DB[3] |
| 11 | GND | GND | +ACKB | +DB[4] |
| 12 | GND | GND | GND | +DB[5] |
| 13 | GND | GND | +REQB | +DB[6] |
| 14 | GND | GND | +DB[16] | +DB[7] |
| 15 | GND | GND | +DB[17] | +DB[P] |
| 16 | GND | GND | +DB[18] | DIFFSENS |
| 17 | TRMPWRB | TRMPWR | TRMPWRB | TRMPWR |
| 18 | TRMPWRB | TRMPWR | TRMPWRB | TRMPWR |
| 19 | GND | GND | +DB[19] | Res. |
| 20 | GND | GND | +DB[20] | +ATN |
| 21 | GND | GND | +DB[21] | GND |
| 22 | GND | GND | +DB[22] | +BSY |
| 23 | GND | GND | +DB[23] | +ACK |
| 24 | GND | GND | +DB[P2] | +RST |
| 25 | GND | GND | +DB[24] | +MSG |
| 26 | GND | GND | +DB[25] | +SEL |
| 27 | GND | GND | +DB[26] | +C/D |
| 28 | GND | GND | +DB[27] | +REQ |
| 29 | GND | GND | +DB[28] | +I/O |
| 30 | GND | GND | +DB[29] | GND |
| 31 | GND | GND | +DB[30] | +DB[8] |
| 32 | GND | GND | +DB[31] | +DB[9] |
| 33 | GND | GND | +DB[P3] | +DB[10] |
| 34 | GND | GND | GND | +DB[11] |
| 35 | GND | -DB[12] | GND | +DB[12] |
| 36 | -DB[8] | -DB[13] | -DB[8] | +DB[13] |
| 37 | -DB[9] | -DB[14] | -DB[9] | +DB[14] |
| 38 | -DB[10] | -DB[15] | -DB[10] | +DB[15] |
| 39 | -DB[11] | -DB[P1] | -DB[11] | +DB[P1] |
| 40 | -DB[12] | -DB[0] | -DB[12] | GND |
| 41 | -DB[13] | -DB[1] | -DB[13] | -DB[0] |
| 42 | -DB[14] | -DB[2] | -DB[14] | -DB[1] |
| 43 | -DB[15] | -DB[3] | -DB[15] | -DB[2] |
| 44 | -DB[P1] | -DB[4] | -DB[P1] | -DB[3] |
| 45 | -ACKB | -DB[5] | -ACKB | -DB[4] |
| 46 | GND | -DB[6] | DIFFSENS | -DB[5] |
| 47 | -REQB | -DB[7] | -REQB | -DB[6] |
| 48 | -DB[16] | -DB[P] | -DB[16] | -DB[7] |
| 49 | -DB[17] | GND | -DB[17] | -DB[P] |
| 50 | -DB[18] | GND | -DB[18] | GND |
| 51 | TRMPWRB | TRMPWR | TRMPWRB | TRMPWR |
| 52 | TRMPWRB | TRMPWR | TRMPWRB | TRMPWR |
| 53 | -DB[19] | Res. | -DB[19] | Res. |
| 54 | -DB[20] | GND | -DB[20] | -ATN |
| 55 | -DB[21] | -ATN | -DB[21] | GND |

| Pin | Single-Ended | | Differential | |
|-----|--------------|---------|--------------|---------|
| | B-Cable | P-Cable | B-Cable | P-Cable |
| 56 | -DB[22] | GND | -DB[22] | -BSY |
| 57 | -DB[23] | -BSY | -DB[23] | -ACK |
| 58 | -DB[P2] | -ACK | -DB[P2] | -RST |
| 59 | -DB[24] | -RST | -DB[24] | -MSG |
| 60 | -DB[25] | -MSG | -DB[25] | -SEL |
| 61 | -DB[26] | -SEL | -DB[26] | -C/D |
| 62 | -DB[27] | -C/D | -DB[27] | -REQ |
| 63 | -DB[28] | -REQ | -DB[28] | -I/O |
| 64 | -DB[29] | -I/O | -DB[29] | GND |
| 65 | -DB[30] | -DB[8] | -DB[30] | -DB[8] |
| 66 | -DB[31] | -DB[9] | -DB[31] | -DB[9] |
| 67 | -DB[P3] | -DB[10] | -DB[P3] | -DB[10] |
| 68 | GND | -DB[11] | GND | -DB[11] |

5.4. 110pin SCSI-Connector (L-Cable)

| Pin | Single-Ended | Differential | Pin | Single-Ended | Differential |
|-----|--------------|--------------|-----|--------------|--------------|
| 1 | GND | GND | 56 | GND | GND |
| 2 | GND | +DB[24] | 57 | -DB[24] | -DB[24] |
| 3 | GND | +DB[25] | 58 | -DB[25] | -DB[25] |
| 4 | GND | +DB[26] | 59 | -DB[26] | -DB[26] |
| 5 | GND | +DB[27] | 60 | -DB[27] | -DB[27] |
| 6 | GND | +DB[28] | 61 | -DB[28] | -DB[28] |
| 7 | GND | +DB[29] | 62 | -DB[29] | -DB[29] |
| 8 | GND | +DB[30] | 63 | -DB[30] | -DB[30] |
| 9 | GND | +DB[31] | 64 | -DB[31] | -DB[31] |
| 10 | GND | +DB[P3] | 65 | -DB[P3] | -DB[P3] |
| 11 | GND | +DB[12] | 66 | -DB[12] | -DB[12] |
| 12 | GND | +DB[13] | 67 | -DB[13] | -DB[13] |
| 13 | GND | +DB[14] | 68 | -DB[14] | -DB[14] |
| 14 | GND | +DB[15] | 69 | -DB[15] | -DB[15] |
| 15 | GND | +DB[P1] | 70 | -DB[P1] | -DB[P1] |
| 16 | GND | GND | 71 | -DB[0] | GND |
| 17 | GND | +DB[0] | 72 | -DB[1] | -DB[0] |
| 18 | GND | +DB[1] | 73 | -DB[2] | -DB[1] |
| 19 | GND | +DB[2] | 74 | -DB[3] | -DB[2] |
| 20 | GND | +DB[3] | 75 | -DB[4] | -DB[3] |
| 21 | GND | +DB[4] | 76 | -DB[5] | -DB[4] |
| 22 | GND | +DB[5] | 77 | -DB[6] | -DB[5] |
| 23 | GND | +DB[6] | 78 | -DB[7] | -DB[6] |
| 24 | GND | +DB[7] | 79 | -DB[P] | -DB[7] |
| 25 | GND | +DB[P] | 80 | GND | -DB[P] |
| 26 | GND | DIFFSENS | 81 | GND | GND |
| 27 | TRMPWR | TRMPWR | 82 | TRMPWR | TRMPWR |
| 28 | TRMPWR | TRMPWR | 83 | TRMPWR | TRMPWR |
| 29 | TRMPWR | TRMPWR | 84 | TRMPWR | TRMPWR |
| 30 | GND | +ATN | 85 | GND | -ATN |
| 31 | GND | GND | 86 | -ATN | GND |
| 32 | GND | +BSY | 87 | GND | -BSY |
| 33 | GND | +ACK | 88 | -BSY | -ACK |
| 34 | GND | +RST | 89 | -ACK | -RST |
| 35 | GND | +MSG | 90 | -RST | -MSG |
| 36 | GND | +SEL | 91 | -MSG | -SEL |
| 37 | GND | +C/D | 92 | -SEL | -C/D |

| Pin | Single-Ended | Differential | Pin | Single-Ended | Differential |
|-----|--------------|--------------|-----|--------------|--------------|
| 38 | GND | +REQ | 93 | -C/D | -REQ |
| 39 | GND | -I/O | 94 | -REQ | -I/O |
| 40 | GND | GND | 95 | -I/O | GND |
| 41 | GND | +DB[8] | 96 | -DB[8] | -DB[8] |
| 42 | GND | +DB[9] | 97 | -DB[9] | -DB[9] |
| 43 | GND | +DB[10] | 98 | -DB[10] | -DB[10] |
| 44 | GND | +DB[11] | 99 | -DB[11] | -DB[11] |
| 45 | GND | GND | 100 | GND | GND |
| 46 | GND | +DB[16] | 101 | -DB[16] | -DB[16] |
| 47 | GND | +DB[17] | 102 | -DB[17] | -DB[17] |
| 48 | GND | +DB[18] | 103 | -DB[18] | -DB[18] |
| 49 | GND | +DB[19] | 104 | -DB[19] | -DB[19] |
| 50 | GND | +DB[20] | 105 | -DB[20] | -DB[20] |
| 51 | GND | +DB[21] | 106 | -DB[21] | -DB[21] |
| 52 | GND | +DB[22] | 107 | -DB[22] | -DB[22] |
| 53 | GND | +DB[23] | 108 | -DB[23] | -DB[23] |
| 54 | GND | +DB[P2] | 109 | -DB[P2] | -DB[P2] |
| 55 | GND | GND | 110 | GND | GND |