

# SERIAL & PARALLEL

## PC-Support Information Pages for the Serial and Parallel Interface

Information page containing data about: RS232 Serial Interface, RS232 Glossary, RS232 Signal Description, RS232 Pin Assignment, RS232 Data Transmission, RS232Null Modem, RS232 Mainboard Connectors, RS232 Loopback Diagnostics. Pin assignment of the Game Port. For the Parallel Printer Interface (Centronics) the following information is available: Pin Assignment, Signals, Output Timing, Loopback Test and Interlink Cable.

Filename : e\_dta-pc-tech-serpar.htm

Location : <http://www.elektroniklager.de/pc-sup>

Copyright, all rights reserved, Eberhard De Wille

**Revision History:**

<b>Date</b>	<b>Version</b>	<b>Revision</b>	<b>Name</b>	<b>Department</b>	<b>Phone</b>	<b>Description of Changes</b>
2004-06-01	1.0	a	Eberhard De Wille	pc-sup	-	First version of the serial and parallel pages

**Table of contents**

1. RS232 Serial Interface..... 4

    1.1. RS232 Glossary ..... 4

    1.2. RS232 Signal Description ..... 4

    1.3. RS232 Pin Assignment ..... 5

    1.4. RS232 Data Transmission ..... 7

        1.4.1. Three Wire (Minimal Connection) between DTE (e.g. PC) and DCE (e.g. modem)..... 8

        1.4.2. Three Wire (Minimal Connection) between DTE (e.g. PC) and DTE (e.g. Plotter)..... 8

        1.4.3. Full Connection (with Hardware-Hand-Shake) between DTE (e.g. PC) and DCE (e.g. Modem)..... 8

    1.5. RS232 Null Modem ..... 9

        1.5.1. Simplified Null Modem Connection ..... 10

        1.5.2. Pin Assignment of the simplified Null Modem ..... 10

    1.6. RS232 Mainboard Connectors..... 10

    1.7. RS232 Loopback Diagnostics..... 11

2. Game Port ..... 13

3. Parallel Printer Interface (Centronics) ..... 14

    3.1. Interface Pin Assignment ..... 16

    3.2. Minimum Connection between parallel PC Interface and Printer ..... 16

    3.3. Signal Description ..... 16

    3.4. Output Timing of the parallel Interface..... 17

    3.5. 25pin D-Sub Loopback Connector..... 18

    3.6. Parallel Interlink Cable (WIN95/WIN98)..... 18

## 1. RS232 Serial Interface

The RS232 transmission protocol was originally developed for data transmission via the telephone line. It was defined that 8-bit data bytes are transmitted. Additionally at the beginning a start bit is sent which marks the start of a data byte. At the end of the byte an additional stop bit is sent. This means that in total 10 bits are sent. The voltage level of a start bit and stop bit is also defined, thus the envelopped user bits are for sure detected. For the transmission of user data the ASCII code (American Standard Code of Information Interchange) was defined so that the information is universal and independent of the type of the data terminals. The interface is designed for the handling and use of modems (**Modulator/Demodulator**) and contains some special signals for this purpose. Applications like the automotive vehicle testers which also use an RS232 interface, however do not need these modem specific signals. For this equipment it is sufficient to use the RD, TD and GND signals. These signals are explained here in detail.

### 1.1. RS232 Glossary

**DCE** = Data Communications Equipment **DCE**. This is another word for modem. This is a device which transforms the data in a way that they can be transmitted via a telephone line. Data Communication Equipment (i.e. modems and level converters) are devices that transmit and receive signals and pass them on to other equipment without any processing.

**DTE** = Data Terminal Equipment. This can be e.g. a computer terminal of a mainframe system, which in fact is the origin of the expression. It can be a printer, plotter or PC, etc. Data Terminal Equipments are devices which transmit and/or receive data and process them without passing them on to other equipment.

**Null Modem** = This expression stands for a RS232 cable connection between two DTEs, which use this transmission protocol, without using modems. This is e.g. the case if a serial printer is connected to a PC. The length of the cable, however, is limited to 10 meters. There are amplifiers available which can be connected in between and allow a much longer cable length. Since there are no modems used, it is necessary to connect the odem specific signals in a certain way to simulate the presence of a modem. The wiring details are described below.

### 1.2. RS232 Signal Description

**RD/RX** = Received data. On this wire the data bits from the data terminal (DTE) are received.

**TD/TX** = Transmitted data. On this wire the data bits are transmitted to the data terminal (DTE).

**CHS GND** = Chassis ground. The data terminal and the modem have to have a common ground, to prevent ground loops.

**DSR** = Data Set Ready. This signal is generated by the modem and means that the modem is active and ready to communicate with the data terminal.

**DTR** = Data Terminal Ready. This signal is generated by the data terminal and transmitted to the modem and means that the data terminal is active and ready to communicate with the modem.

**DCD/CD** = Data Carrier Detect or Carrier Detect. This signal shows that the modems on both sides are connected via the telephone line and are ready to interchange data.

**RTS** = Request To Send. This signal is generated by the data terminal and means that the terminal wants to transmit data.

**CTS** = Clear To Send. This is the response signal from the modem to the data terminal (following a RTS) and signals that the modem is ready to receive the data from the data terminal and transform them for the telephone line.

**SIG GND** = Signal ground. This ground is the reference ground for all signals. Depending on the equipment this can be a separate ground or it can be connected to the chassis ground.

**RI** = Ring Indicator. Is a signal from the modem to the data terminal which indicates that an external call is coming in on the telephone line. I.e. the telephone is "ringing". Depending on the application the receiver is "lifted off". The number of rings until lifting off can be set in the modem.

### 1.3. RS232 Pin Assignment

View upon the D-SUB 25 pin female connector (socket)

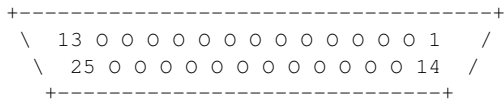

View upon the D-SUB 25 pin male connector (plug)

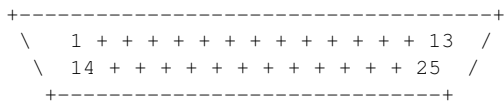

View upon the D-SUB 9 pin female connector (socket)

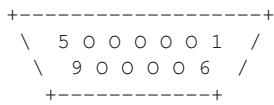

View upon the D-SUB 9 pin male connector (plug)

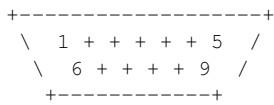

Signal Name	Function	Direction PC (DTE) < > DCE	25 pin D-SUB	9 pin D-SUB
GND	Chassis - Ground	< >	1	-
TxD	Transmit Data	>	2	3
RxD	Receive Data	<	3	2
RTS	Request to Send	>	4	7
CTS	Clear to Send	<	5	8
DSR	Data Set Ready	<	6	6
GND	Signal - Ground	< >	7	5
DCD	Data Carrier Detect	<	8	1
DTR	Data Terminal Ready	>	20	4
RI	Ring Indicator	<	22	9
-	Not used	-	9, 10, 11, 12, 13, 14, 15, 16, 17, 18, 19, 21, 23, 24, 25	-

The pin assignment in this table can be used as a wiring schematic for an adapter between the two types of connectors.

### 1.4. RS232 Data Transmission

#### 1.4.1. Three Wire (Minimal Connection) between DTE (e.g. PC) and DCE (e.g. modem)

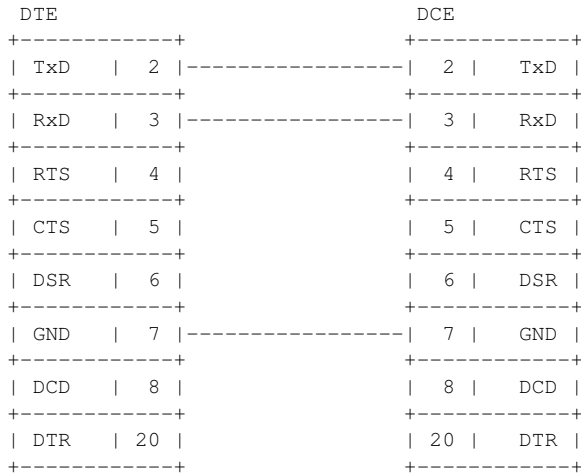

#### 1.4.2. Three Wire (Minimal Connection) between DTE (e.g. PC) and DTE (e.g. Plotter)

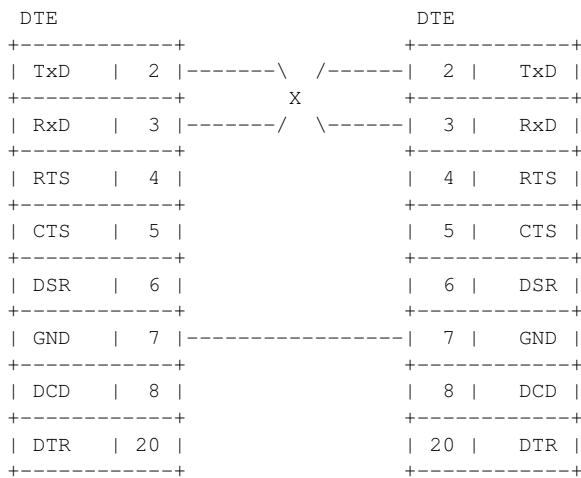

To achieve a safe data transmission via a three wire connection a method should be used in which blocks of data are transmitted and a checksum is calculated for each block. Another possibility is to use the "software handshake" with the Xon (ASCII: 11h) / Xoff (ASCII: 13h) protocol.

**1.4.3. Full Connection (with Hardware-Hand-Shake) between DTE (e.g. PC) and DCE (e.g. Modem)**

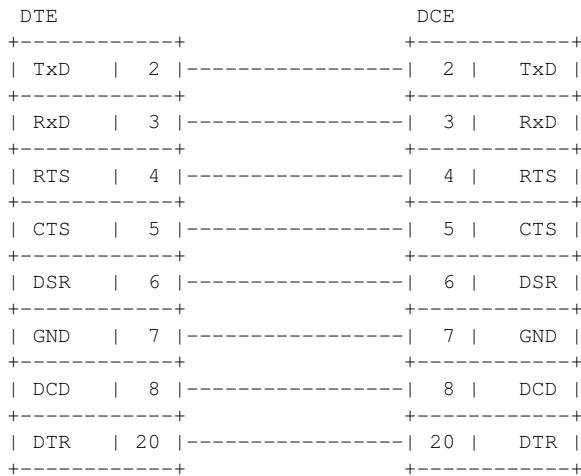

**1.5. RS232 Null Modem**

This is a full connection (with Hardware-Hand-Shake) between DTE (e.g. PC) and DTE (e.g. plotter). All other pins are not used. This cable can also be used to connect two PCs to exchange data (interlink cable WIN98 / WIN95)

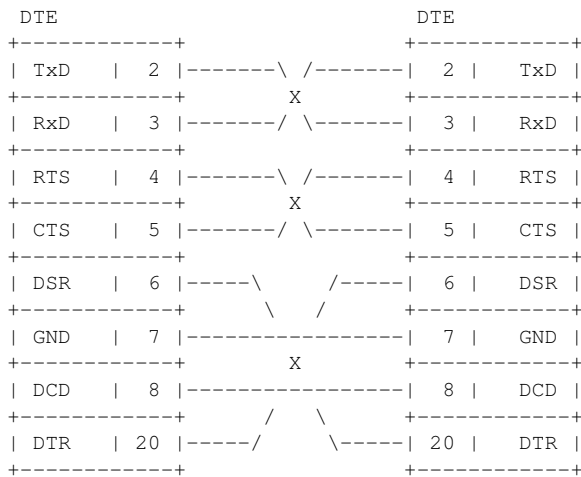

Here is another table using the 9pin connectors

DB-9	DB-25		DB-25	DB-9	Signals
3	2	<--->	3	2	Xmit-Recv data
2	3	<--->	2	3	Recv-Xmit data
7	4	<--->	5	8	RTS-CTS
8	5	<--->	4	7	CTS-RTS
1&6	6	<--->	20	4	DSR-DTR
5	7	<--->	7	5	Gnd-Gnd
4	20	<--->	6	1&6	DTR-DSR

### 1.5.1. Simplified Null Modem Connection

**DTR to DSR and DCD of the own interface.** DTR is set if the data terminal is switched on and ready. This signal generates now the DSR signal which simulates to the data terminal, that the modem is ready. Additionally the DTS signal is connected to the DCD input of the interface, which simulates to the data terminal, that the modem is connected to the modem of the communication partner and that data can be transmitted.

**RTS to CTS of the own interface.** If the data terminal wants to transmit a byte, it sets the RTS signal and expects as a response from the modem the CTS signal. If both pins are connected it is simulated to the interface of the DTE that data can be transmitted.

**TD to RD of the communication partner.** The transmit line of the first communication equipment has to be connected to the receive line of the second communication equipment and vice versa. Additionally the signal ground and the chassis ground have to be connected between the two stations.

### 1.5.2. Pin Assignment of the simplified Null Modem

PC with 25pin D-Sub Connector	PC with 9pin D-Sub Connector		Printer / Plotter with 25pin D-Sub Connector
5 (CTS)	8 (CTS)	---->	6 to 8 to 20 (DTR/DSR/CD)
3 (RD)	2 (RD)	<----	2 (TD)
2 (TD)	3 (TD)	---->	3 (RD)
7 (SIG GND)	5 (SIG GND)	<--->	7 (SIG GND)
6 to 8 to 20 (DTR/DSR/CD) Connected inside the own connector, without any connection to the other communication partner!	1 to 4 to 6 (DTR/DSR/CD) Connected inside the own connector, without any connection to the other communication partner!		4 to 5 (RTS to CTS) Connected inside the own connector, without any connection to the other communication partner!

**Attention!** In this case the DTR signal of the printer is connected to the CTS signal of the PC. By this it can be achieved, that in case of an error condition at the printer (e.g. out of paper) the CTS of the PC is deactivated, so that no data are lost. This can be regarded as the "Light" version of the full hardware handshake version.

**1.6. RS232 Mainboard Connectors**

The serial RS232 output of some mainboards (10pol. DIL) is wired with a flat cable to the connectors in the back of the housing. Two variants of this are known.

**IBM Assignment:**

DIL	DB-9	DB-25	Function
1	1	8	DCD
6	2	3	RX
2	3	2	TX
7	4	20	DTR
3	5	7	GND
8	6	6	DSR
4	7	4	RTS
9	8	5	CTS
5	9	22	RI
10	10		N/C OR KEY

**Everex Assignment:**

DIL	DB9	DB-25	Function
1	1	8	DCD
2	2	3	RX
3	3	2	TX
4	4	20	DTR
5	5	7	GND
6	6	6	DSR
7	7	4	RTS
8	8	5	CTS
9	9	22	RI
10	10		N/C OR KEY

### **1.7. RS232 Loopback Diagnostics**

Using the following wiring a test adapter can be made to check the function of the RS232 interface e.g. in a PC.

#### **25pin D-Sub female loopback connector (socket)**

2 to 3 (TxD to RxD)

4 to 5 to 22 (RTS to CTS to RI)

6 to 8 to 20 (DSR to CD to DTR)

#### **9pin D-Sub female loopback connector (socket)**

2 to 3 (TxD to RxD)

7 to 8 to 9 (RTS to CTS to RI)

6 to 1 to 4 (DSR to CD to DTR)

## 2. Game Port

Pin	Signal
1	+5V DC
2	Button 4 (A_PB1)
3	Position 0 (A_X)
4	GND
5	GND
6	Position 1 (A_Y)
7	Button 5 (A_PB2)
8	+5V DC
9	+5V DC
10	Button 6 (B_PB1)
11	Position 2 (B_X)
12	GND
13	Position (B_Y)
14	Button 7 (B_PB2)
15	+5V DC

### **3. Parallel Printer Interface (Centronics)**

The parallel interface is also called Centronics interface. It is mainly designed for printers with Centronics interface, but can also be used for other peripheral devices with this interface.

Via the parallel interface 8 data bits can be transmitted simultaneously. Additionally there are some control signals to handle a correct data transmission.

The interface contains 12 buffered output lines (8 data lines, strobe, printer initialize, auto feed, select input) and 5 input lines (acknowledge, busy, paper end, error, select), which are generated by the printer.

Block diagram of the parallel interface

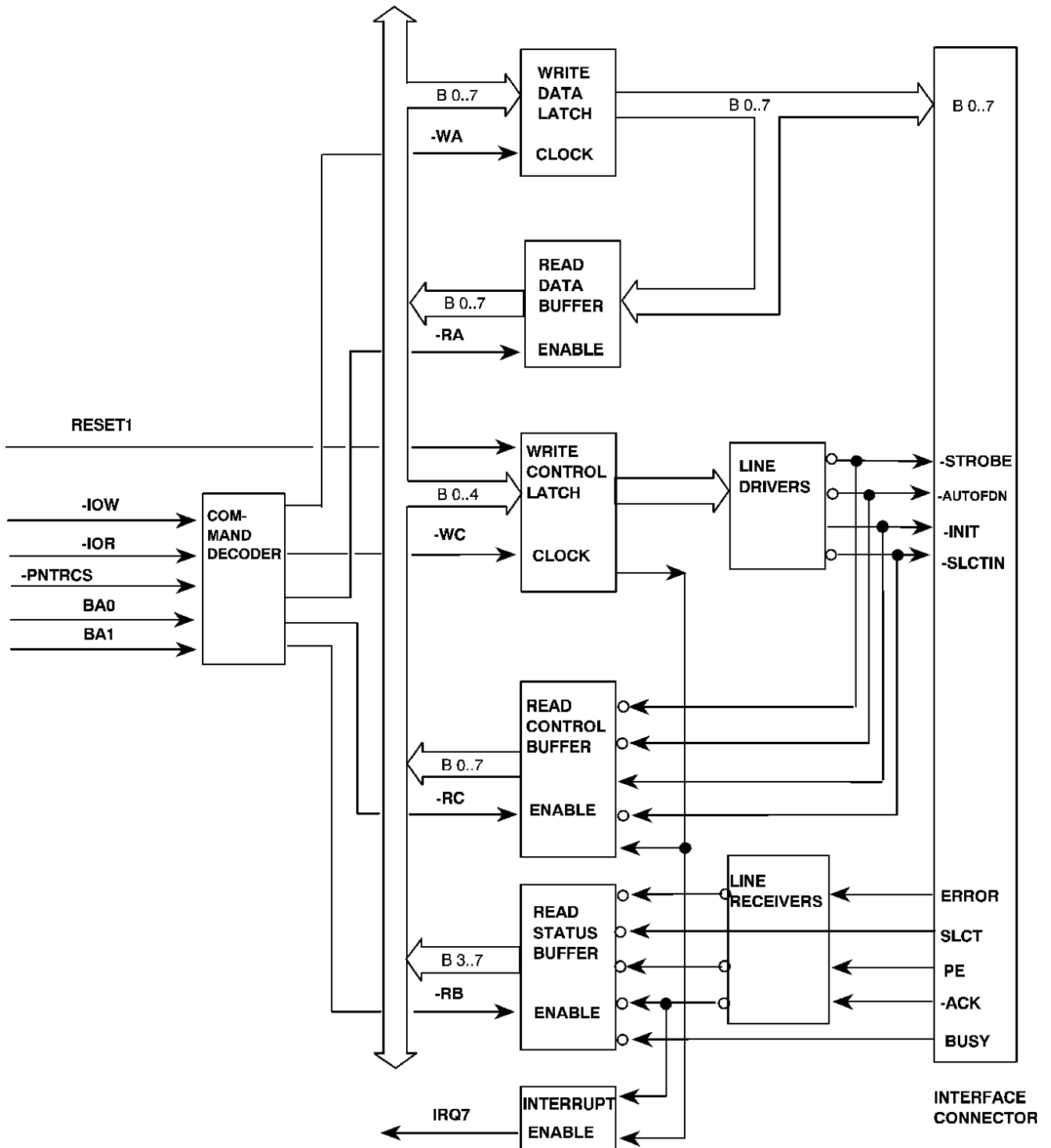

**Signal level:**

High = +5V, Low = 0V

3.1. Interface Pin Assignment

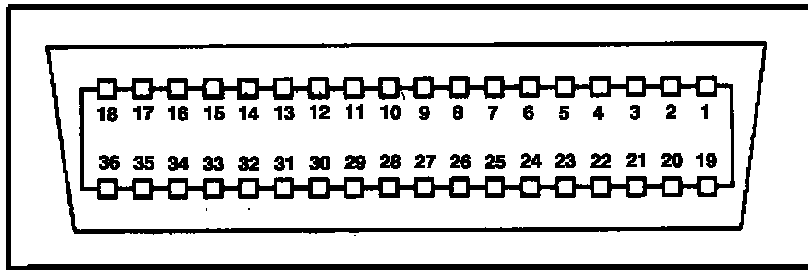
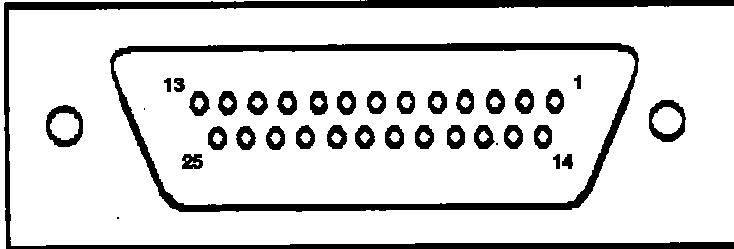

**Top:** IBM connector 25 pin D-SUB female connector (socket) at the PC  
**Bottom:** Centronics connector 36 pin female connector (socket) at the printer

3.2. Minimum Connection between parallel PC Interface and Printer

D-SUB connector 25 pin <-----> Centronics connector 36 pin

-STROBE	1	-----	-STROBE	1
Data 0	2	-----	Data 0	2
Data 1	3	-----	Data 1	3
Data 2	4	-----	Data 2	4
Data 3	5	-----	Data 3	5
Data 4	6	-----	Data 4	6
Data 5	7	-----	Data 5	7
Data 6	8	-----	Data 6	8
Data 7	9	-----	Data 7	9
-ACK	10	-----	-ACK	10
BUSY	11	-----	BUSY	11
PE	12	-----	PE	12
GND	18	-----	GND	30

### 3.3. Signal Description

Pin Cen- tronics	Pin D-SUB 25pin	Signal Source > PC < Device	Signal Name	Function
1	1	>	-STROBE	-Strobe = "0" data are transmitted to the printer
2	2	↔	Data 0	data line 0
3	3	↔	Data 1	data line 1
4	4	↔	Data 2	data line 2
5	5	↔	Data 3	data line 3
6	6	↔	Data 4	data line 4
7	7	↔	Data 5	data line 5
8	8	↔	Data 6	data line 6
9	9	↔	Data 7	data line 7
10	10	<	-ACK	-ACK = "0" the last character was accepted by the printer and a new one can be transmitted now
11	11	<	BUSY	BUSY = "1" the printer is not able to receive new data
12	12	<	PE	PE = "1" the printer ran out of paper
13	13	<	SLCT	SLCT = "1" the printer is online
14	14	>	-AUTOFDX	-AUTOFDX = "1" command to the printer to perform a line feed
15	-		-	not used
16	18	↔	GND	Signal ground
17	-	↔	GND	Chassis ground
18	-	<	+5V	+5V from the printer
19	-	↔	GND	Ground twisted with -STROBE
20	-	↔	GND	Ground twisted with Data 0
21	-	↔	GND	Ground twisted with Data 1
22	-	↔	GND	Ground twisted with Data 2
23	-	↔	GND	Ground twisted with Data 3
24	-	↔	GND	Ground twisted with Data 4
25	-	↔	GND	Ground twisted with Data 5
26	-	↔	GND	Ground twisted with Data 6
27	-	↔	GND	Ground twisted with Data 7
28	-	↔	GND	Ground twisted with -ACK
29	-	↔	GND	Ground twisted with BUSY
30	19	↔	GND	Ground
31	16	>	-INIT	-INIT = "0" initializes the printer and clears the printer buffer
32	15	<	-ERROR	-ERROR = "0" the printer is in error mode
33	20	↔	GND	
34	-		-	not used
35	-	<	-	Pull Up to +5V
36	17	>	-SLCTIN	-SLCTIN = "0" enables the printer to receive new data
-	21, 22 23, 24 25	↔	GND	Ground

Remark: The "minus" character (-) in front of a signal means that this signal is "low active".

### 3.4. Output Timing of the parallel Interface

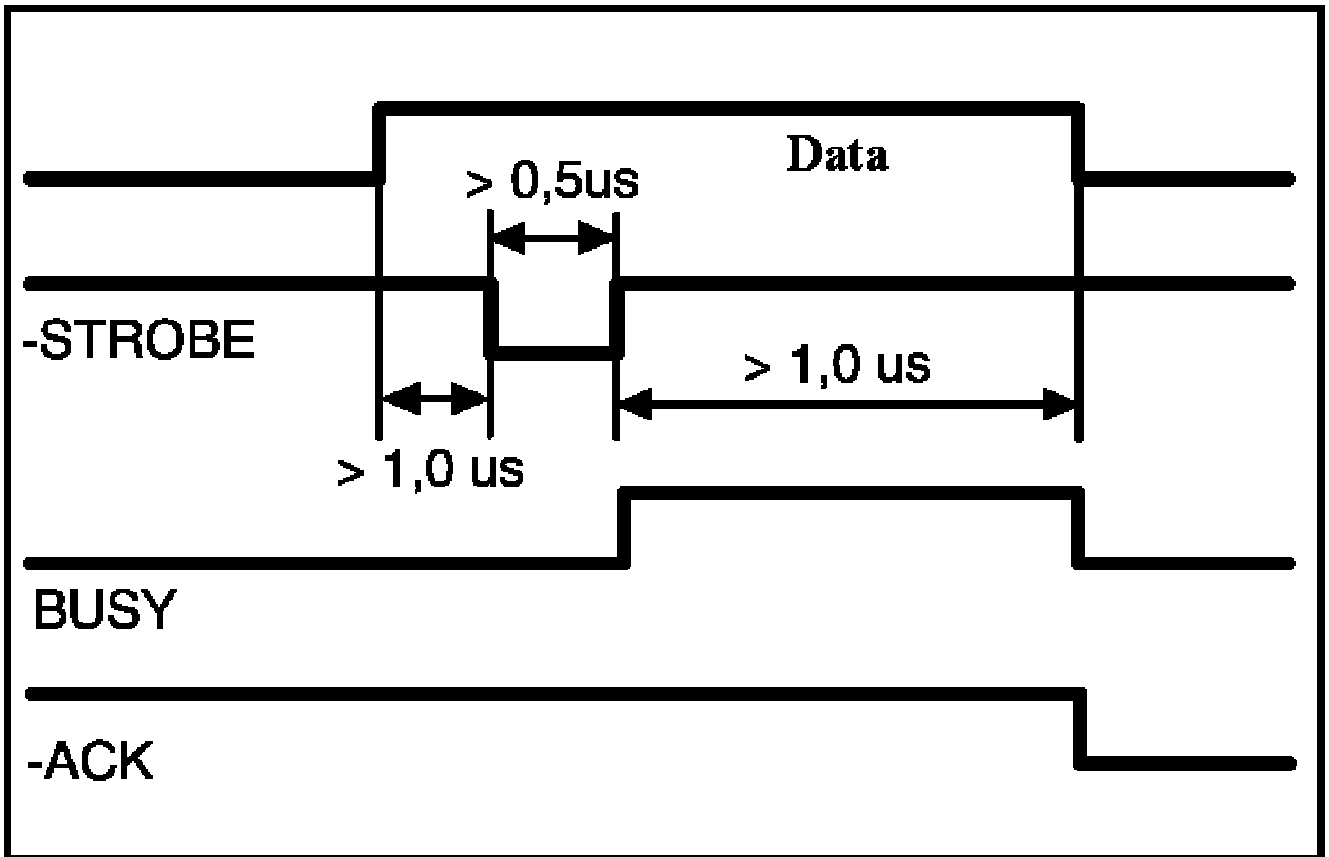

Timing of the signal lines at the output of data via the parallel interface.

### 3.5. 25pin D-Sub Loopback Connector

Using the following connector wiring a test adapter can be made to check the function of a parallel interface at the PC.

- 1 to 13 (strobe to select)
- 2 to 15 (data0 to ERROR)
- 10 to 16 (ACK to INIT)
- 11 to 17 (BUSY to SLCTIN)
- 12 to 14 (PAPER END to AUTOFEED)

**3.6. Parallel Interlink Cable (WIN95/WIN98)**

With this cable a communication connection between two PCs can be set up e.g. for WIN95, WIN98 or various transmission programs:

DB-25(plug)		DB-25(plug)
2	<---->	15
3	<---->	13
4	<---->	12
5	<---->	10
6	<---->	11
15	<---->	2
13	<---->	3
12	<---->	4
10	<---->	5
11	<---->	6
25	<---->	25